

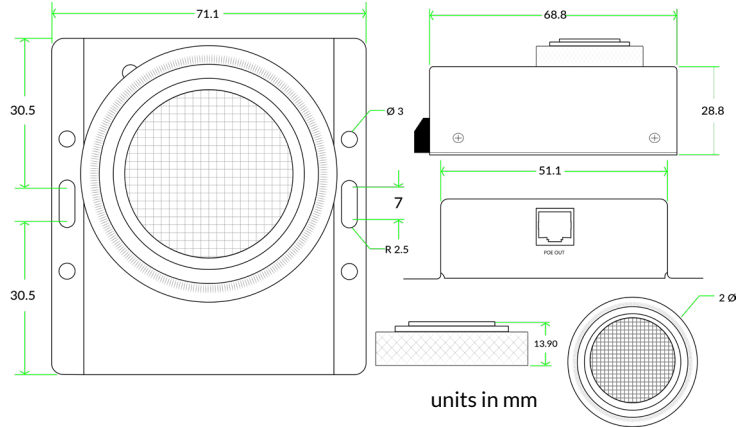

# H2, VOC, Temperature and Humidity Sensor (GAS-H2-VOC)



Self calibrating standalone sensor designed for monitoring offgas and H2 in stationary battery systems. Factory calibrated. Self calibrating, no in field calibration required.

## Certification and Calibration:

Certification	cULus 61010-1
VOC	Factory calibrated
H2	Factory calibrated. Self calibrating over life span
Temperature	Factory calibrated (ISO 17025 certificate optionally available)
Humidity	Factory calibrated (as per 17025 standards)

## Sensor Metrics:

VOC measurement output range	0-500 VOC Index
VOC repeatability	<±5 VOC index points or % mass volume (m.v.)
H2 detection range	0-100% LEL
H2 accuracy	±5% LEL
Temperature measurement range	-40°C to 125°C (-40°F to 257°F)
Temperature accuracy	±0.48°C (0.86 °F)
Relative humidity measurement range	0 to 100% RH
Relative humidity accuracy	2% RH
Response time (T90)	<30 seconds

## Technical Specifications:

Powered by and communicates with	Base Unit (BASE-XX) (required) Requires the optional BASE-FW-SLS firmware add on for the Base Unit
Connectivity	RJ45 cable transmitting data & power from Base Unit to Sensor
Cable specification	RJ45 CAT 6/7 recommended Up to 100m (330ft) subject to cable quality & interference
Sensor power usage	492mW
Detection method	Spectrometer
Life span	up to 10 years

## Environmental Specifications:

Operating temperature range	-30°C to +60°C (-22°F to 140°F)
Humidity (operating and storage)	< 90% rH (non-condensating)

## Physical Specifications:

Sensor enclosure	Steel enclosure, industrial grade
Mounting option	OU rack, DIN rail, magnetic, or wall mountable sensor
Dimensions	71.1mm (2.8") x 68.8mm (2.71") x 28.8 mm (1.13")
Weight	193g (0.43lb)



# Flammable Gas Sensor (R-GAS-FLAMMABLE)

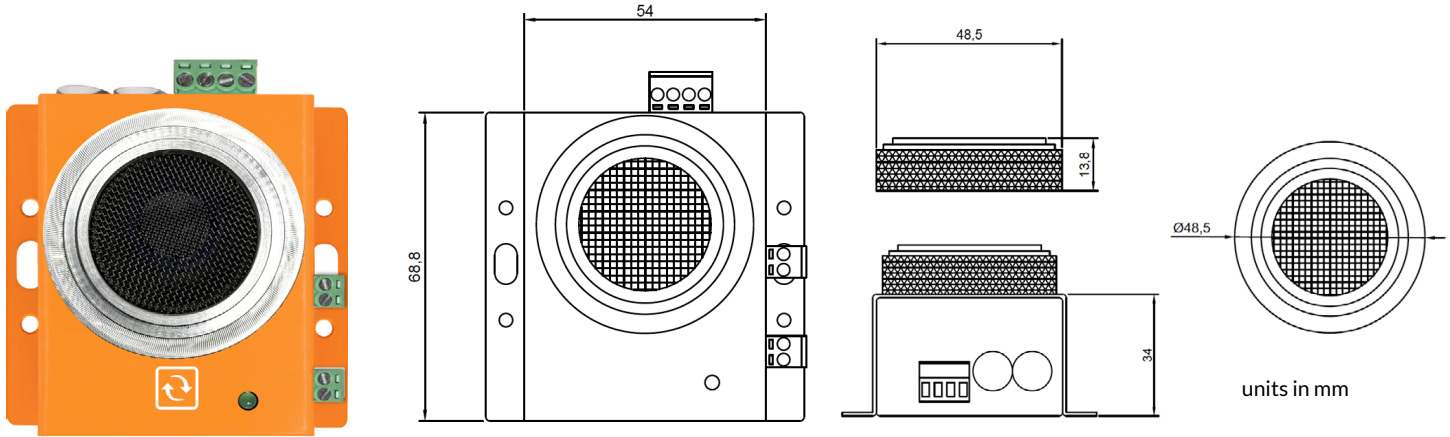

Sensor designed for monitoring flammable gases. User settable address (RS485) out of 256 possibilities. Factory calibrated.

## Certification and Calibration:

Certification	On-going ETL 2075 listing (preliminary design review)
Flammable gas	Factory calibrated
Internal temperature	Factory calibrated (ISO 17025 certificate optionally available)
Internal humidity	Factory calibrated (as per 17025 standards)

## Sensor Metrics:

Flammable gas detection range	0-100% LEL
Accuracy	±5% LEL
Temperature measurement range	-40°C to 125°C (-40°F to 257°F)
Internal temperature accuracy	±0.48°C (0.86°F)
Relative humidity measurement range	0 to 100% RH
Relative humidity accuracy	2% RH
Response time (T90)	<30 seconds

## Technical Specifications:

Relay outputs	2 (Normally Open)
Relay switching current	up to 0.5A
Input Voltage	12-24V DC
Power usage	312mW - 672mW
Protocol	Modbus RTU over RS485
	Integration with Base Unit over RJ45 (serial data)
Detection method	Spectrometer
Life span	up to 10 years

## Environmental Specifications:

Operating temperature range	-30°C to +60°C (-22°F to 140°F)
Humidity (operating and storage)	< 90% rH (non-condensating)

## Physical Specifications:

Sensor enclosure	Steel enclosure, industrial grade
Mounting option	OU rack, DIN rail, magnetic, or wall mountable sensor
Dimensions	68.8mm (2.71") x 54mm (2.13") x 34 mm (1.34")
Weight	193g (0.43lb)